

# LOW PROFILE

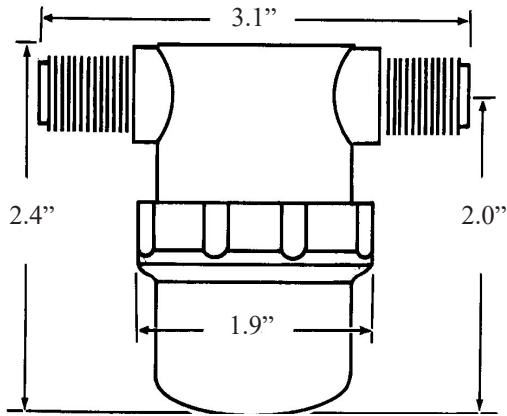

FILTER AREA - 3.95 SQ IN

### HOW TO ORDER

1. TOP	MPT(RVM) 1/4(44)	FPT(RVLF) 3/8(66)	HB(RVB) 1/2(88)
	POLY(P)		NYLON(N)
2. GASKET	EPDM(E)	VITON(V)	BUNA(B)
3. SCREEN	20M(20)	40M(40)	80M(80)
4. BOWL	POLY(P)	NYLON(N)	CLEAR(C)

EXAMPLE: RVM 44 P E 40 P

## POLYPRO (L.P. Standard Assy)

ListEA  
**\$ 11.16**

1. POLY TOP (RVM)
2. EPDM OR BUNA GASKET (RVM44GB OR E)
3. 20,40, OR 80 MESH SCREEN (RVM44 \_)
4. CLEAR BOWL (RVM44BC)

### OPTIONS

- |                                    |          |
|------------------------------------|----------|
| 1. FEMALE TOPS (RVLF)              | add 1.30 |
| 1. BARB TOP (RVB)                  | add .73  |
| 2. VITON GASKET (RVM44GV)          | add 1.48 |
| 3. 20, 40, OR 80 MESH CAGED SCREEN | add .84  |
| 3. 250 MESH CAGED SCREEN           | add 1.78 |
| 4. POLY BOWL (RVM44BP)             | add .32  |

## NYLON (L.P. Standard Assy)

ListEA  
**\$ 11.16**

1. NYLON TOP (RVM)
2. EPDM OR BUNA GASKET (RVM44GB OR E)
3. 20,40, OR 80 MESH SCREEN (RVM44 \_)
4. CLEAR BOWL (RVM44BC)

### OPTIONS

- |                                    |          |
|------------------------------------|----------|
| 1. FEMALE TOPS (RVLF)              | add 3.19 |
| 1. BARB TOP (RVB)                  | add .73  |
| 2. VITON GASKET (RVM44GV)          | add 1.48 |
| 3. 20, 40, OR 80 MESH CAGED SCREEN | add .84  |
| 3. 250 MESH CAGED SCREEN           | add 1.78 |
| 4. NYLON BOWL (RVM44BN)            | add 1.58 |

### CAGED SCREENS (MESH)

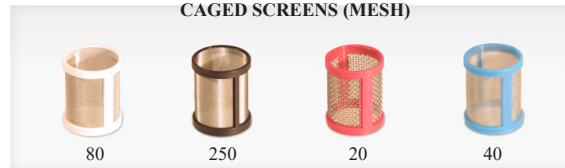

### LOW PROFILE STRAINER PARTS

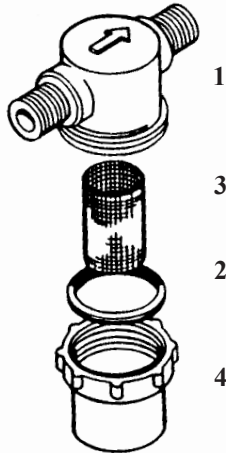

COMPONENT(1)	SIZE/PORT	NYLON #	LIST/EA	POLYPRO #	LIST/EA	
TOP	1/8" MPT	RVM22TN	4.56	RVM22TP	4.56	
TOP	1/4" MPT	RVM44TN	4.56	RVM44TP	4.56	
TOP	3/8" MPT	RVM66TN	4.56	RVM66TP	4.56	
TOP	1/2" MPT	RVM88TN	4.56	RVM88TP	4.56	
TOP	1/4" HB	RVB44TN	5.29	RVB44TP	5.29	
TOP	3/8" HB	RVB66TN	5.29	RVB66TP	5.29	
TOP	1/2" HB	RVB88TN	5.29	RVB88TP	5.29	
TOP	1/8" FPT	RVLF22TN	7.75	RVLF22TP	5.87	
TOP	1/4" FPT	RVLF44TN	7.75	RVLF44TP	5.87	
TOP	3/8" FPT	RVLF66TN	7.75	RVLF66TP	5.87	
TOP	1/2" FPT	RVLF88TN	7.75	RVLF88TP	5.87	
COMPONENT(2)	MATERIAL	TEMP MIN	COLOR	PART #	LIST/EA	
GASKET	BUNA	0 F	BLACK	RVM44GB	.51	
GASKET	EPDM	-40 F	RED	RVM44GE	.51	
GASKET	VITON	10 F	GREEN	RVM44GV	1.99	
COMPONENT(3)	MATERIAL	MESH*	MICRON+	ID" x L"	PART #	LIST/EA
SCREEN	ST STEEL	20	915	.94 x 1.34	RVM4420	2.15
SCREEN	ST STEEL CAGED	20	915	"	RVM4420C	2.99
SCREEN	ST STEEL	40	480	"	RVM4440	2.15
SCREEN	ST STEEL CAGED	40	480	"	RVM4440C	2.99
SCREEN	ST STEEL	80	178	"	RVM4480	2.15
SCREEN	ST STEEL CAGED	80	178	"	RVM4480C	2.99
SCREEN	ST STEEL	100	80	"	RVM44100	5.66
SCREEN	ST STEEL	250	40	"	RVM44250	5.71
SCREEN	ST STEEL CAGED	250	40	"	RVM44250C	3.93
SCREEN	POLYETH	90			RVM4490PE	3.83
COMPONENT(4)	MATERIAL	PART #	LIST/EA			
BOWL	NYLON	RVM44BN	5.51			
BOWL	POLYPRO	RVM44BP	4.25			
BOWL	CLEAR NYLON	RVM44BC	3.93			

\*Mesh is defined as the number of wires per linear inch measured from center of wire to center of wire.

+Micron is defined as one thousandth of a millimeter.

# MINI STRAINER

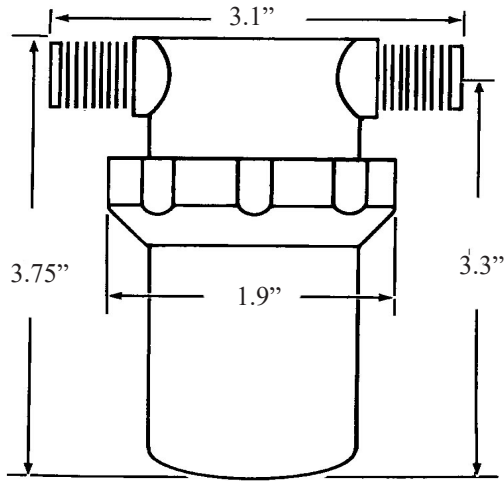

FILTER AREA - 7.71 SQ IN

### HOW TO ORDER

1. TOP	MPT(RVM) 1/4(445)	FPT(RVLF) 3/8(665)	HB(RVB) 1/2(885)
	POLY(P) NYLON(N)		
2. GASKET	EPDM(E)	VITON(V)	BUNA(B)
3. SCREEN	20M(20)	40M(40)	80M(80)
4. BOWL	POLY(P)	NYLON(N)	CLEAR(C)

EXAMPLE: RVM 445 P E 40 P

## POLYPRO (Standard Assy)

ListEA

\$ 15.98

1. POLY TOP (RVM)
2. EPDM OR BUNA GASKET (RVM44GB OR E)
3. 20 OR 40 MESH SCREEN (RVM445 \_\_)
4. CLEAR BOWL (RVM445BC)

### OPTIONS

- |                                   |          |
|-----------------------------------|----------|
| 1. FEMALE TOPS (RVLF)             | add 1.31 |
| 1. BARB TOP (RVB)                 | add .73  |
| 2. VITON GASKET (RVM44GV)         | add 1.48 |
| 3. 80 MESH STAINLESS SCREEN       | add .58  |
| 3. 20,40, OR 80 MESH CAGED SCREEN | add .43  |
| 3. 250 MESH CAGED SCREEN          | add 1.62 |
| 4. POLY BOWL (RVM445BP)           | add 1.01 |

## NYLON (Standard Assy)

ListEA

\$ 15.98

1. NYLON TOP (RVM)
2. EPDM OR BUNA GASKET (RVM44GB OR E)
3. 20 OR 40 MESH SCREEN (RVM445 \_\_)
4. CLEAR BOWL (RVM445BC)

### OPTIONS

- |                                   |          |
|-----------------------------------|----------|
| 1. FEMALE TOPS (RVLF)             | add 3.19 |
| 1. BARB TOP (RVB)                 | add .73  |
| 2. VITON GASKET (RVM44GV)         | add 1.48 |
| 3. 80 MESH STAINLESS SCREEN       | add .58  |
| 3. 20,40, OR 80 MESH CAGED SCREEN | add .43  |
| 3. 250 MESH CAGED SCREEN          | add 1.62 |
| 4. NYLON BOWL (RVM445BN)          | add 1.37 |

### CAGED SCREENS (MESH)

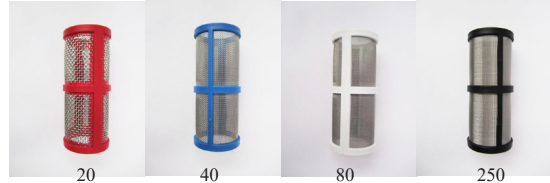

MINI STRAINER PARTS						
COMPONENT(1)	SIZE/PORT	NYLON #	LIST/EA	POLYPRO #	LIST/EA	
TOP	1/8" MPT	RVM22TN	4.56	RVM22TP	4.56	
TOP	1/4" MPT	RVM44TN	4.56	RVM44TP	4.56	
TOP	3/8" MPT	RVM66TN	4.56	RVM66TP	4.56	
TOP	1/2" MPT	RVM88TN	4.56	RVM88TP	4.56	
TOP	1/4" HB	RVB44TN	5.29	RVB44TP	5.29	
TOP	3/8" HB	RVB66TN	5.29	RVB66TP	5.29	
TOP	1/2" HB	RVB88TN	5.29	RVB88TP	5.29	
TOP	1/8" FPT	RVLF22TN	7.75	RVLF22TP	5.87	
TOP	1/4" FPT	RVLF44TN	7.75	RVLF44TP	5.87	
TOP	3/8" FPT	RVLF66TN	7.75	RVLF66TP	5.87	
TOP	1/2" FPT	RVLF88TN	7.75	RVLF88TP	5.87	
COMPONENT(2)	MATERIAL	TEMP MIN	COLOR	PART #	LIST/EA	
GASKET	BUNA	0 F	BLACK	RVM44GB	.51	
GASKET	EPDM	-40 F	RED	RVM44GE	.51	
GASKET	VITON	10 F	GREEN	RVM44GV	1.99	
COMPONENT(3)	MATERIAL	MESH*	MICRON+	ID" x L"	PART #	LIST/EA
SCREEN	ST STEEL	20	915	.94 x 2.63	RVM44520	3.04
SCREEN	ST STEEL CAGED	20	915	"	RVM44520C	3.47
SCREEN	ST STEEL	40	480	"	RVM44540	3.04
SCREEN	ST STEEL CAGED	40	480	"	RVM44540C	3.47
SCREEN	ST STEEL	80	178	"	RVM44580	3.62
SCREEN	ST STEEL CAGED	80	178	"	RVM44580C	3.47
SCREEN	ST STEEL	250	40	"	RVM445250	15.40
SCREEN	ST STEEL CAGED	250	40	"	RVM445250C	4.66
COMPONENT(4)	MATERIAL	PART #	LIST/EA			
BOWL	NYLON	RVM445BN	8.64			
BOWL	POLYPRO	RVM445BP	8.28			
BOWL	CLEAR NYLON	RVM445BC	7.27			

\*Mesh is defined as the number of wires per linear inch measured from center of wire to center of wire.

+Micron is defined as one thousandth of a millimeter.

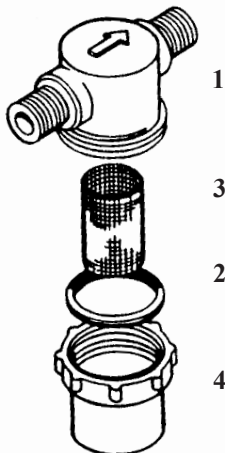

MINI STRAINER

# INTERMEDIATE STRAINER

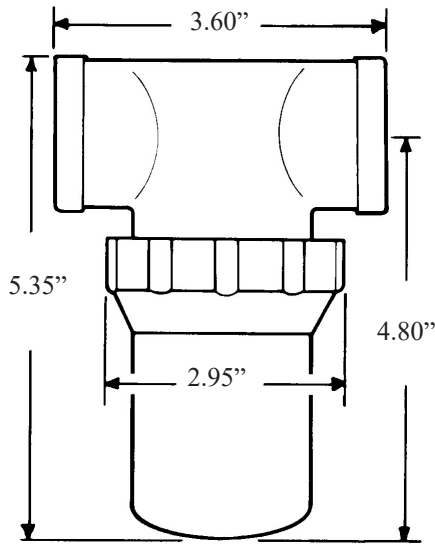

FILTER AREA - 17.33 SQ IN

### HOW TO ORDER

1. TOP	FPT(RVF)	TAB(RVT-POLY ONLY)	
	3/8"(66)	1/2"(88)	3/4"(1212)
	POLY(P)	NYLON(N)	
2. GASKET	EPDM(E)	VITON(V)	BUNA(B)
3. SCREEN	20M(20)	40M(40)	80M(80)
4. BOWL	POLY(P)	NYLON(N)	CLEAR(C)

EXAMPLE: RVF 88 N V 40 C

## POLYPRO (Standard Assembly) List/EA

1. POLY TOP (RVF)
2. EPDM GASKET(RVF66GE)
3. 20 OR 40 MESH SCREEN(RVF66\_)
4. POLY BOWL(RVF66BP)

**\$ 18.06**

### OPTIONS

- |                                      |          |
|--------------------------------------|----------|
| 1. TAB TOP (RVT)                     | add 1.00 |
| 2. BUNA GASKET (RVF66GB)             | add .42  |
| 2. VITON GASKET (RVF66GV)            | add 3.52 |
| 3. 80 MESH SCREEN (RVF6680S)         | add .89  |
| 3. 20,40, OR 80 MESH CAGED SCREEN    | add .27  |
| 3. 100 MESH SCREEN (RVF66100)        | add 2.26 |
| 3. 250 MESH CAGED SCREEN (RVF66250C) | add 3.00 |
| 3. CAGED POLY SCREEN (RVF66_P)       | add 5.30 |
| 4. CLEAR NYLON BOWL (RVF66BC)        | add 8.58 |

## NYLON (Standard Assembly) List/EA

**\$ 25.35**

1. NYLON TOP (RVF)
2. EPDM GASKET (RVF66GE)
3. 20 OR 40 MESH SCREEN(RVF66\_)
4. NYLON BOWL (RVF66BN)

### OPTIONS

- |                                      |          |
|--------------------------------------|----------|
| 2. BUNA GASKET (RVF66GB)             | add .42  |
| 2. VITON GASKET (RVF66GV)            | add 3.52 |
| 3. 80 MESH SCREEN (RVF6680S)         | add .89  |
| 3. 20, 40, OR 80 MESH CAGED SCREEN   | add .27  |
| 3. 100 MESH SCREEN (RVF66100)        | add 2.26 |
| 3. 250 MESH CAGED SCREEN (RVF66250C) | add 3.00 |
| 4. CLEAR NYLON BOWL (RVF66BC)        | add 6.01 |

### CAGED SCREENS (MESH)

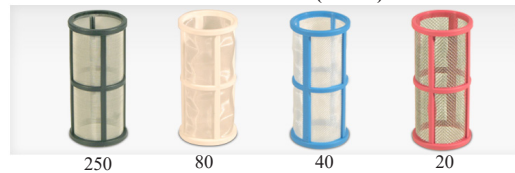

### INTERMEDIATE STRAINER PARTS

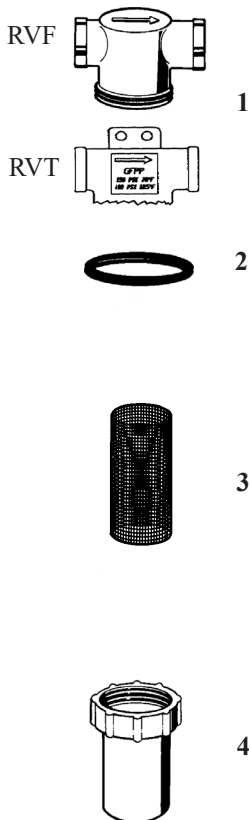

COMPONENT(1)	SIZE/PORT	NYLON #	PRICE	POLYPRO #	LIST/EA	
TOP	3/8" FPT	RVF66TN	11.11	RVF66TPN	6.40	
TOP	1/2" FPT	RVF88TN	11.11	RVF88TPN	6.40	
TOP	3/4" FPT	RVF1212TN	11.11	RVF1212TPN	6.40	
TOP	1" FPT	RVF1616TN*	11.11	RVF1616TP*	6.40	
TOP	3/8" FPT TAB			RVT66TP	7.40	
TOP	1/2" FPT TAB			RVT88TP	7.40	
TOP	3/4" FPT TAB			RVT1212TP	7.40	
COMPONENT(2)	MATERIAL	TEMP MIN	COLOR	PART #	LIST/EA	
GASKET	BUNA	0 F	BLACK	RVF66GB	1.10	
GASKET	EPDM	-40 F	RED	RVF66GE	.68	
GASKET	VITON	10 F	GREEN	RVF66GV	4.20	
COMPONENT(3)	MATERIAL	MESH*	MICRON+	ID" x L"	PART #	LIST/EA
SCREEN	ST STEEL	20	915	1.49 x 3.75	RVF6620S	4.08
SCREEN	ST STEEL	40	480	"	RVF6640S	4.08
SCREEN	ST STEEL	80	178	"	RVF6680S	4.97
SCREEN	ST STEEL	100	80	"	RVF66100	6.34
SCREEN	ST STEEL	250	40	"	RVF66250	19.32
SCREEN	POLYETHYLENE		90	1.00 x 3.52	RVF6690PE	7.50
SCREEN	CAGED ST	20	915	1.49 x 3.75	RVF6620C	4.35
SCREEN	CAGED ST	40	480	"	RVF6640C	4.35
SCREEN	CAGED ST	80	178	"	RVF6680C	4.35
SCREEN	CAGED ST	250	40	"	RVF66250C	7.08
SCREEN	CAGED POLY	20	915	"	RVF6620P	9.13
SCREEN	CAGED POLY	40	480	"	RVF6640P	9.38
SCREEN	CAGED POLY	80	178	"	RVF6680P	9.38
*Mesh is defined as the number of wires per linear inch measured from center of wire to center of wire.						
+Micron is defined as one thousandth of a millimeter						
COMPONENT(4)	MATERIAL	COLOR	PART #	LIST/EA		
BOWL	NYLON	WHITE	RVF66BN	9.49		
BOWL	POLYPRO	BLACK	RVF66BP	6.92		
BOWL	CLEAR NYLON	CLEAR	RVF66BC	15.50		

INT. STRAINERS

# LARGE STRAINER

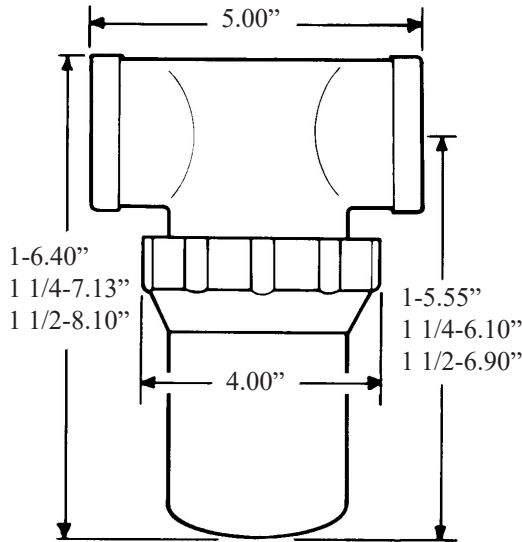

## FILTER AREA:

1" - 29.73 SQ IN  
 1 1/4" - 31.84 SQ IN  
 1 1/2" - 38.27 SQ IN

## HOW TO ORDER

1. TOP FPT=RVF  
 1=1616 1 1/4=2020 1 1/2=2424  
 POLY=P NYLON=N  
 2.GASKET EPDM=E VITON=V BUNA=B  
 3.SCREEN 20M=20 40M=40 80M=80  
 4.BOWL POLY=P NYLON=N CLEAR=C

EXAMPLE: RVF 1616 N V 40 N

PLEASE NOTE: ALL LARGE STRAINERS  
 USE THE SAME GASKET & BOWL

## POLYPRO (Std Assembly)

List/EA

1. POLY TOP 1" \$ 35.14
2. EPDM OR BUNA GASKET 1 1/4" \$ 35.76
3. 20 OR 40 MESH SCREEN 1 1/2" \$ 36.29
4. POLY BOWL(RVF1616BP)

## OPTIONS

2. VITON GASKET (RVF1616GV) add 4.66
3. 20, 40, OR 80 MESH CAGED SCREEN (1") add 2.73
3. 20, 40, OR 80 MESH CAGED SCREEN (1 1/4") add 2.37
3. 20, 40, OR 80 MESH CAGED SCREEN (1 1/2") add 2.09
4. CLEAR NYLON BOWL (RVF1616BC) add 17.13

## NYLON (Std Assembly)

List/EA

1. NYLON TOP 1" \$ 48.76
2. EPDM OR BUNA GASKET 1 1/4" \$ 49.39
3. 20 OR 40 MESH SCREEN 1 1/2" \$ 49.90
4. NYLON BOWL(RVF1616BN)

## OPTIONS

2. VITON GASKET (RVF1616GV) add 4.66
3. 20, 40, OR 80 MESH CAGED SCREEN (1") add 2.73
3. 20, 40, OR 80 MESH CAGED SCREEN (1 1/4") add 2.37
3. 20, 40, OR 80 MESH CAGED SCREEN (1/12") add 2.09
4. CLEAR NYLON BOWL (RVF1616BC) add 9.73

## CAGED SCREENS (MESH)



## LARGE STRAINER PARTS

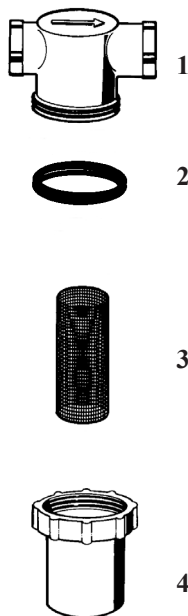

COMPONENT(1)	SIZE/PORT	NYLON #	PRICE	POLYPRO #	LIST/EA	
TOP	1" FPT	RVF1616TN	23.36	RVF1616TP	17.13	
TOP	1 1/4" FPT	RVF2020TN	23.36	RVF2020TP	17.13	
TOP	1 1/2" FPT	RVF2424TN	23.36	RVF2424TP	17.13	
COMPONENT(2)	MATERIAL	TEMP MIN	COLOR	PART #	LIST/EA	
GASKET	BUNA	0 F	BLACK	RVF1616GB	1.05	
GASKET	EPDM	-40 F	RED	RVF1616GE	1.05	
GASKET	VITON	10 F	GREEN	RVF1616GV	5.71	
COMPONENT(3)	MATERIAL	MESH*	MICRON+	ID" x L"	PART #	LIST/EA
SCREEN-1"	ST STEEL	20	915	2.24 x 4.24	RVF161620	5.60
SCREEN-1"	ST STEEL CAGED	20	915	"	RVF161620C	8.33
SCREEN-1"	ST STEEL	40	480	"	RVF161640	5.60
SCREEN-1"	ST STEEL CAGED	40	480	"	RVF161640C	8.33
SCREEN-1"	ST STEEL CAGED	80	178	"	RVF161680C	8.33
SCREEN-1 1/4"	ST STEEL	20	915	2.24 x 4.54	RVF202020	6.23
SCREEN-1 1/4"	ST STEEL CAGED	20	915	"	RVF202020C	8.60
SCREEN-1 1/4"	ST STEEL	40	480	"	RVF202040	6.23
SCREEN-1 1/4"	ST STEEL CAGED	40	480	"	RVF202040C	8.60
SCREEN-1 1/4"	ST STEEL CAGED	80	178	"	RVF202080C	8.60
SCREEN-1 1/2"	ST STEEL	20	915	2.24 x 5.45	RVF242420	6.76
SCREEN-1 1/2"	ST STEEL CAGED	20	915	"	RVF242420C	8.85
SCREEN-1 1/2"	ST STEEL	40	480	"	RVF242440	6.76
SCREEN-1 1/2"	ST STEEL CAGED	40	480	"	RVF242440C	8.85
SCREEN-1 1/2"	ST STEEL CAGED	80	178	"	RVF242480C	8.85
*Mesh is defined as the number of wires per linear inch measured from center of wire to center of wire.						
+Micron is defined as one thousandth of a millimeter						
COMPONENT(4)	MATERIAL	COLOR	PART #	LIST/EA		
BOWL	NYLON	WHITE	RVF1616BN	18.76		
BOWL	POLYPRO	BLACK	RVF1616BP	11.36		
BOWL	CLEAR NYLON	CLEAR	RVF1616BC	28.49		



**SUCTION LINE STRAINERS**  
 MOLDED PVC BASE  
 ST. STEEL SCREENS

Fpt	Mesh	Part #	List/E
1/4	20	RV663-20	5.82
1/4	40	RV663	5.82
1/4	80	RV663-80	6.35
1/4	100	RV663-100	6.35
3/8	40	RV6631	6.42
3/8	80	RV6631-80	6.42
1/2	40	RV6632	7.66
1/2	80	RV6632-80	7.66
3/4	40	RV6633	8.37
1	40	RV6634	12.17
1 1/2	40	RV6636	14.37



**Y STRAINERS**  
 POLYPROPYLENE BODY  
 EPDM GASKET  
 (VITON AVAILABLE)  
 ST. STEEL SCREENS  
 FPT THREADS

Fpt	Part #	List/E
1/2	YST88PE_P	80.75
3/4	YST1212PE_P	80.75
1	YST1616PE_P	80.75
1 1/4	YST2020PE_P	80.75
1 1/2	YST2424PE_P	CALL
2	YST3232PE_P	CALL
3	YST4848PE_P	CALL

Please specify screen when ordering. See parts list below for sizes.

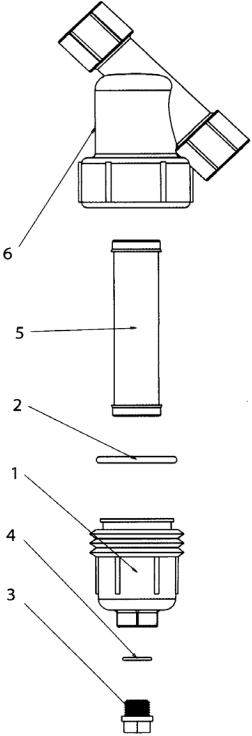

Y STRAINER PARTS						
COMPONENT(1,2,6)		SIZE		PART #	LIST/E	
BODY, CAP & EPDM GASKET		1/2		YST88-B/C	41.83	
BODY, CAP & EPDM GASKET		3/4		YST1212-B/C	41.83	
BODY, CAP & EPDM GASKET		1		YST1616-B/C	41.83	
BODY, CAP & EPDM GASKET		1 1/4		YST2020-B/C	41.83	
BODY, CAP & EPDM GASKET		1 1/2		YST2424-B/C	93.75	
BODY, CAP & EPDM GASKET		2		YST3232-B/C	93.75	
BODY, CAP & EPDM GASKET		3		YST4848-B/C	842.04	
COMPONENT(2) MATERIAL		SIZE		PART #	LIST/E	
GASKET	VITON	1/2 & 3/4		YST88-GV	13.08	
GASKET	VITON	1 & 1 1/4		YST1616-GV	15.08	
GASKET	VITON	1 1/2 & 2		YST2424-GV	29.88	
GASKET	VITON	3		YST4848-GV	69.13	
COMPONENT(5) MAT		SIZE	MESH	MICRON	PART #	LIST/E
SCREEN	ST STEEL	1/2 & 3/4	20	841	YST88-20	53.25
SCREEN	"	"	40	446	YST88-40	48.42
SCREEN	"	"	80	177	YST88-80	53.25
SCREEN	ST STEEL	1 & 1 1/4	20	841	YST1616-20	53.25
SCREEN	"	"	40	446	YST1616-40	53.25
SCREEN	"	"	80	177	YST1616-80	48.42
SCREEN	ST STEEL	1 1/2 & 2	6	3360	YST3232-6	105.38
SCREEN	"	"	8	2380	YST3232-8	90.58
SCREEN	"	"	12	1680	YST3232-12	95.79
SCREEN	"	"	20	841	YST3232-20	95.79
SCREEN	"	"	30	595	YST3232-30	95.79
SCREEN	"	"	50	297	YST3232-50	95.79
SCREEN	"	"	80	177	YST3232-80	95.79
SCREEN	"	"	120	116	YST3232-120	105.38
SCREEN	POLYPRO	"	20	841	YST3232-20	95.79
SCREEN	POLYPRO	"	50	297	YST3232-50	95.79
SCREEN	ST STEEL	3	4		YST4848-4	317.17
SCREEN	"	"	8	2380	YST4848-8	317.17
SCREEN	"	"	12	1680	YST4848-12	317.17
SCREEN	"	"	20	841	YST4848-20	288.29
SCREEN	"	"	50	297	YST4848-50	288.29